

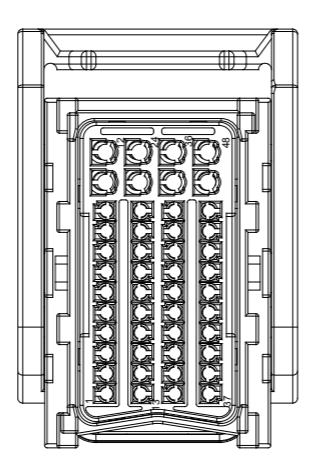

INSTALL COVER WITH THE FAN RELAY BY THE REFERENCE KEY HOLE



ECU
3100068
RET 3109661
RET 3109658
DCAP 3109671

| Pos | CKT | CBL | GA | COL | Type | Cav/Plug | Term |
|-----|-----|----------|----|----------|------|----------|---------|
| 1 | 54 | | 18 | YEL/BLK | TXL | - | 2308221 |
| 2 | 65 | KTWIST 1 | 18 | YEL | TXL | - | 2308221 |
| 3 | 64 | KTWIST 1 | 18 | GRN | TXL | - | 2308221 |
| 4 | 5 | | 18 | LGRN/RED | TXL | - | 2308221 |
| 5 | 6 | | 18 | BLU/YEL | TXL | - | 2308221 |
| 6 | 15 | | 18 | GRN/YEL | TXL | - | 2308221 |
| 7 | 73 | | 18 | ORG | TXL | - | 2308221 |
| 8 | - | - | - | - | - | 3104871 | - |
| 9 | 52 | | 18 | BLK | TXL | - | 2308221 |
| 10 | 72 | | 18 | ORG/WHIT | TXL | - | 2308221 |
| 11 | 39 | | 18 | PNK | TXL | - | 2308652 |
| 12 | 51 | | 18 | BLK/YEL | TXL | - | 2308652 |
| 13 | - | - | - | - | - | 3104871 | - |
| 14 | - | - | - | - | - | 3104871 | - |
| 15 | - | - | - | - | - | 3104871 | - |
| 16 | 86 | | 18 | PUR/BLK | TXL | - | 2308221 |
| 17 | - | - | - | - | - | 3104871 | - |
| 18 | 60 | | 20 | WHT/YEL | TXL | - | 2308221 |
| 19 | 56 | | 18 | GRY/RED | TXL | - | 2308221 |
| 20 | 91 | | 18 | WHT | TXL | - | 2308221 |
| 21 | - | - | - | - | - | 3104871 | - |
| 22 | 59 | | 18 | BLK/WHIT | TXL | - | 2308221 |
| 23 | 95 | | 18 | LGRN/RED | TXL | - | 2308652 |
| 24 | 94 | | 18 | BLK/BLU | TXL | - | 2308652 |

| Pos | CKT | CBL | GA | COL | Type | Cav/Plug | Term |
|-----|-----|-----|----|----------|------|----------|---------|
| 25 | - | - | - | - | - | - | 3104871 |
| 26 | - | - | - | - | - | - | 3104871 |
| 27 | 55 | | 18 | GRY/RED | TXL | - | 2308221 |
| 28 | 68 | | 18 | GRN/BLK | TXL | - | 2308221 |
| 29 | - | - | - | - | - | - | 3104871 |
| 30 | 8 | | 20 | GRN/BRN | TXL | - | 2308221 |
| 31 | 9 | | 18 | WHT/BRN | TXL | - | 2308221 |
| 32 | 109 | | 18 | PUR | TXL | - | 2308221 |
| 33 | 92 | | 18 | RED | TXL | - | 2308221 |
| 34 | - | - | - | - | - | - | 3104871 |
| 35 | 83 | | 18 | BLK/WHIT | TXL | - | 2308652 |
| 36 | 128 | | 18 | BLK | TXL | - | 2308652 |
| 37 | 2 | | 18 | YEL | TXL | - | 2308221 |
| 38 | 124 | | 18 | RED | TXL | - | 2308221 |
| 39 | 67 | | 18 | BRN/BLK | TXL | - | 2308221 |
| 40 | 69 | | 18 | BLU/BLK | TXL | - | 2308221 |
| 41 | 70 | | 18 | BLK/YEL | TXL | - | 2308221 |
| 42 | 71 | | 18 | YEL/RED | TXL | - | 2308221 |
| 43 | 96 | | 18 | WHT | TXL | - | 2308221 |
| 44 | 90 | | 18 | BLU | TXL | - | 2308221 |
| 45 | - | - | - | - | - | - | 3104871 |
| 46 | 93 | | 18 | BLU/WHIT | TXL | - | 2308221 |
| 47 | 57 | | 18 | BLU/GRN | TXL | - | 2308652 |
| 48 | 129 | | 18 | BLK | TXL | - | 2308652 |

| Pos | CKT | GA | COL | Type | Term |
|-----|-----|----|----------|------|---------|
| 1 | 53 | 18 | PUR/YEL | GXL | 2313002 |
| 2 | 30 | 18 | BLK | TXL | 2313002 |
| 3 | 17 | 18 | GRN/WHIT | TXL | 2313002 |
| 4 | 226 | 18 | GRY | TXL | 2313002 |

FUEL PUMP
3110401

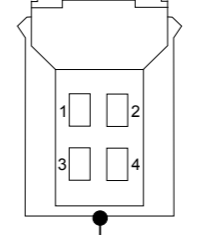

REFERENCE KEY HOLE

INSTALL COMPONENTS IN CLOSE

- RELAY 4411274 - 6
- RELAY 4411275 - 3
- CKT BRKR 4237020 - 1
- FUSE 4205010 - 5
- FUSE 4205020 - 4
- FUSE 4205003 - 2

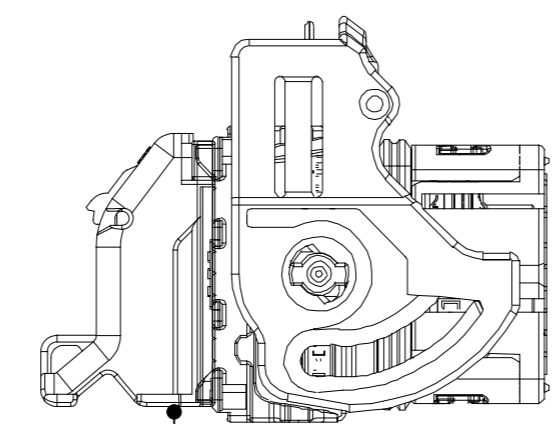

4.00

4.00

16.00

13.00

8.00

10.00

2.00

2.00

2.00

LABEL - 7210921 LABEL

| Pos | CKT | GA | COL |
|-----|-----|----|-----|
| L | 128 | 18 | BLK |
| L | 129 | 18 | BLK |
| R | 127 | 16 | BLK |

| Pos | CKT | GA | COL | Type | Term | Seal |
|-----|-----|----|-----|------|---------|------|
| 1 | 231 | 6 | RED | SGT | 2104006 | - |

| Pos | CKT | GA | COL | Type | Term | Seal |
|-----|-----|----|-----|------|---------|------|
| 1 | 231 | 6 | RED | SGT | 2104006 | - |

| Pos | CKT | GA | COL |
|-----|-----|----|-----|
| L | 127 | 16 | BLK |
| L | 182 | 18 | BLK |
| L | 183 | 18 | BLK |
| L | 184 | 18 | BLK |
| L | 185 | 18 | BLK |
| L | 189 | 18 | BLK |
| R | 197 | 16 | BLK |
| R | 187 | 18 | BLK |
| R | 188 | 18 | BLK |

| Pos | CKT | GA | COL |
|-----|-----|----|-----|
| L | 121 | 16 | RED |
| L | 133 | 16 | RED |
| L | 147 | 12 | RED |
| R | 144 | 10 | RED |

| Pos | CKT | GA | COL |
|-----|-----|----|-----|
| L | 145 | 12 | RED |
| L | 147 | 12 | RED |
| R | 144 | 10 | RED |

| Pos | CKT | GA | COL |
|-----|-----|----|---------|
| L | 62 | 16 | RED/BLU |
| L | 119 | 16 | RED/BLU |
| L | 120 | 16 | RED/BLU |

| Pos | CKT | GA | COL |
|-----|-----|----|-----|
| L | 140 | 12 | RED |
| L | 142 | 12 | RED |
| R | 139 | 10 | RED |

| Pos | CKT | GA | COL |
|-----|-----|----|---------|
| L | 82 | 16 | RED/BLU |
| L | 119 | 16 | RED/BLU |
| L | 120 | 16 | RED/BLU |

| Pos | CKT | GA | COL |
|-----|-----|----|-----|
| L | 140 | 12 | RED |
| L | 142 | 12 | RED |
| R | 139 | 10 | RED |

| Pos | CKT | GA | COL |
|-----|-----|----|---------|
| L | 150 | 18 | RED/BLU |
| L | 151 | 18 | RED/BLU |
| R | 181 | 18 | RED/BLU |
| R | 210 | 18 | ORG |

| Pos | CKT | GA | COL |
|-----|-----|----|---------|
| L | 150 | 18 | RED/BLU |
| L | 151 | 18 | RED/BLU |
| R | 181 | 18 | RED/BLU |
| R | 210 | 18 | ORG |

| Pos | CKT | GA | COL |
|-----|-----|----|---------|
| L | 150 | 18 | RED/BLU |
| L | 151 | 18 | RED/BLU |
| R | 181 | 18 | RED/BLU |
| R | 210 | 18 | ORG |

| Pos | CKT | GA | COL |
|-----|-----|----|---------|
| L | 150 | 18 | RED/BLU |
| L | 151 | 18 | RED/BLU |
| R | 181 | 18 | RED/BLU |
| R | 210 | 18 | ORG |

| Pos | CKT | GA | COL |
|-----|-----|----|---------|
| L | 150 | 18 | RED/BLU |
| L | 151 | 18 | RED/BLU |
| R | 181 | 18 | RED/BLU |
| R | 210 | 18 | ORG |

| Pos | CKT | GA | COL |
|-----|-----|----|---------|
| L | 150 | 18 | RED/BLU |
| L | 151 | 18 | RED/BLU |
| R | 181 | 18 | RED/BLU |
| R | 210 | 18 | ORG |

| Pos | CKT | GA | COL |
|-----|-----|----|---------|
| L | 150 | 18 | RED/BLU |
| L | 151 | 18 | RED/BLU |
| R | 181 | 18 | RED/BLU |
| R | 210 | 18 | ORG |

| Pos | CKT | GA | COL | Type | Cav/Plug | Term | Seal |
|-----|-----|----|----------|------|----------|---------|---------|
| 1 | 36 | 16 | RED/YEL | TXL | - | 2308855 | 2308905 |
| 2 | - | - | - | - | - | 3108922 | - |
| 3 | 35 | 18 | PNK | GXL | - | 2308855 | 2308905 |
| 4 | 146 | 12 | RED/GRN | TXL | - | 2309506 | 2308865 |
| 5 | - | - | - | - | - | 3108922 | - |
| 6 | 154 | 18 | WHT | GXL | - | 2308855 | 2308905 |
| 7 | 59 | 18 | BLK/WHIT | TXL | - | 2308855 | 2308904 |
| 8 | - | - | - | - | - | 3108922 | - |
| 9 | 66 | 16 | PUR | TXL | - | 2308855 | 2308905 |
| 10 | 182 | 18 | BLK | GXL | - | 2308855 | 2308905 |
| 11 | - | - | - | - | - | 3108922 | - |
| 12 | 158 | 12 | ORG | TXL | - | 2309506 | 2308865 |
| 13 | 148 | 12 | RED/GRN | TXL | - | 2309506 | 2308865 |
| 14 | - | - | - | - | - | 3108922 | - |
| 15 | 157 | 18 | WHT | GXL | - | 2308855 | 2308905 |
| 16 | 141 | 12 | RED/GRN | TXL | - | 2309506 | 2308865 |
| 17 | - | - | - | - | - | 3108922 | - |
| 18 | 155 | 18 | WHT | GXL | - | 2308855 | 2308905 |
| 19 | 183 | 18 | BLK | GXL | - | 2308855 | 2308905 |
| 20 | - | - | - | - | - | 3108922 | - |
| 21 | 159 | 12 | ORG | TXL | - | 2309506 | 2308865 |
| 22 | 184 | 18 | BLK | GXL | - | 2308855 | 2308905 |
| 23 | - | - | - | - | - | 3108922 | - |
| 24 | 207 | 12 | ORG | TXL | - | 2309506 | 2308865 |
| 25 | 143 | 12 | RED/GRN | TXL | - | 2309506 | 2308865 |
| 26 | - | - | - | - | - | 3108922 | - |
| 27 | 156 | 18 | WHT | GXL | - | 2308855 | 2308905 |
| 28 | 245 | 18 | ORG | GXL | - | 2308855 | 2308905 |
| 29 | - | - | - | - | - | 3108922 | - |

| Pos | CKT | GA | COL | Type | Cav/Plug | Term | Seal |
|-----|-----|----|----------|------|----------|---------|---------|
| 30 | 220 | 18 | PNK/BLU | GXL | - | 2308855 | 2308905 |
| 31 | 185 | 18 | BLK | GXL | - | 2308855 | 2308905 |
| 32 | - | - | - | - | - | 3108922 | - |
| 33 | 14 | 12 | ORG | TXL | - | 2309506 | 2308865 |
| 34 | 246 | 18 | ORG | GXL | - | 2308855 | 2308905 |
| 35 | 244 | 18 | TAN | GXL | - | 2308855 | 2308905 |
| 36 | - | - | - | - | - | 3108922 | - |
| 37 | 120 | 16 | RED/BLU | TXL | - | 2308855 | 2308905 |
| 38 | 119 | 16 | RED/BLU | TXL | - | 2308855 | 2308905 |
| 39 | 63 | 16 | RED/GRN | TXL | - | 2308855 | 2308905 |
| 40 | 37 | 18 | PNK | GXL | - | 2308855 | 2308905 |
| 41 | 271 | 18 | ORG | GXL | - | 2308855 | 2308905 |
| 42 | 272 | 18 | ORG | GXL | - | 2308855 | 2308905 |
| 43 | 72 | 18 | ORG/WHIT | TXL | - | 2308855 | 2308904 |
| 44 | 132 | 18 | PNK | GXL | - | 2308855 | 2308904 |
| 45 | 52 | 18 | BLK | TXL | - | 2308855 | 2308904 |
| 46 | 53 | 18 | PUR/YEL | GXL | - | 2308855 | 2308905 |
| 47 | 273 | 18 | BLU | GXL | - | 2308855 | 2308905 |
| 48 | 274 | 18 | WHT/BLU | GXL | - | 2308855 | 2308905 |
| 49 | - | - | - | - | - | 3108922 | - |
| 50 | - | - | - | - | - | 3108922 | - |
| 51 | - | - | - | - | - | 3108922 | - |
| 52 | - | - | - | - | - | 3108922 | - |
| 53 | - | - | - | - | - | 3108922 | - |
| 54 | - | - | - | - | - | 3108922 | - |
| 55 | - | - | - | - | - | 3108922 | - |
| 56 | - | - | - | - | - | 3108922 | - |
| 57 | - | - | - | - | - | 3108922 | - |
| 58 | - | - | - | - | - | 3108922 | - |

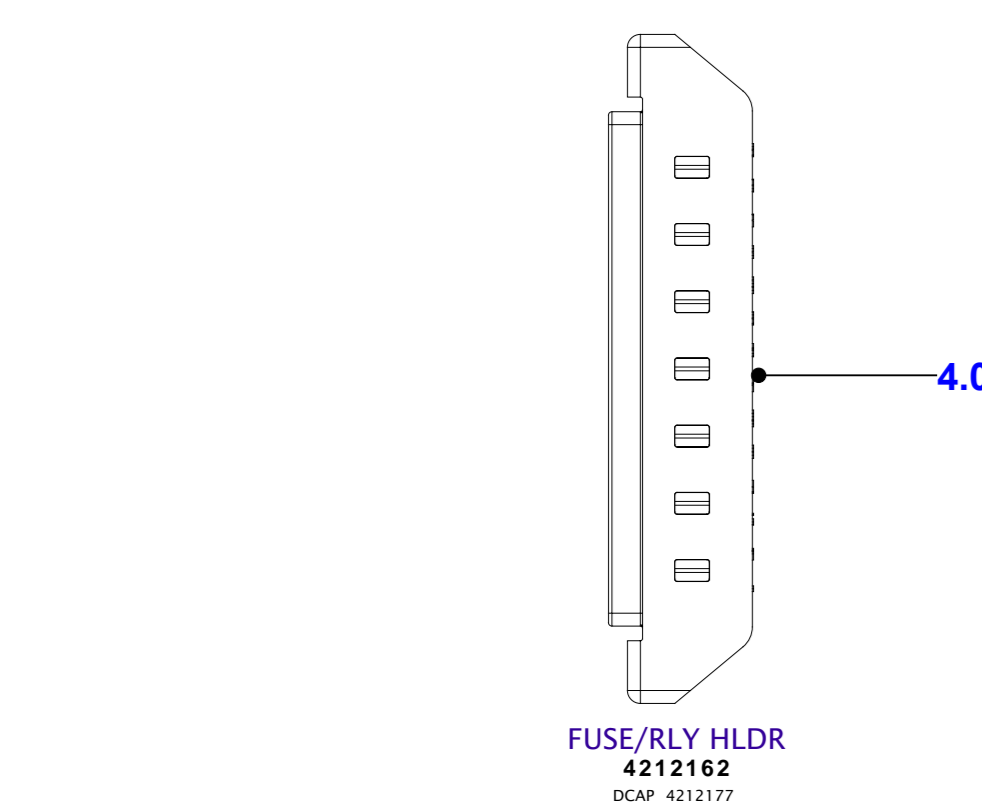

SEE FIG. 1 FOR COMPONENT LOADING VIEW

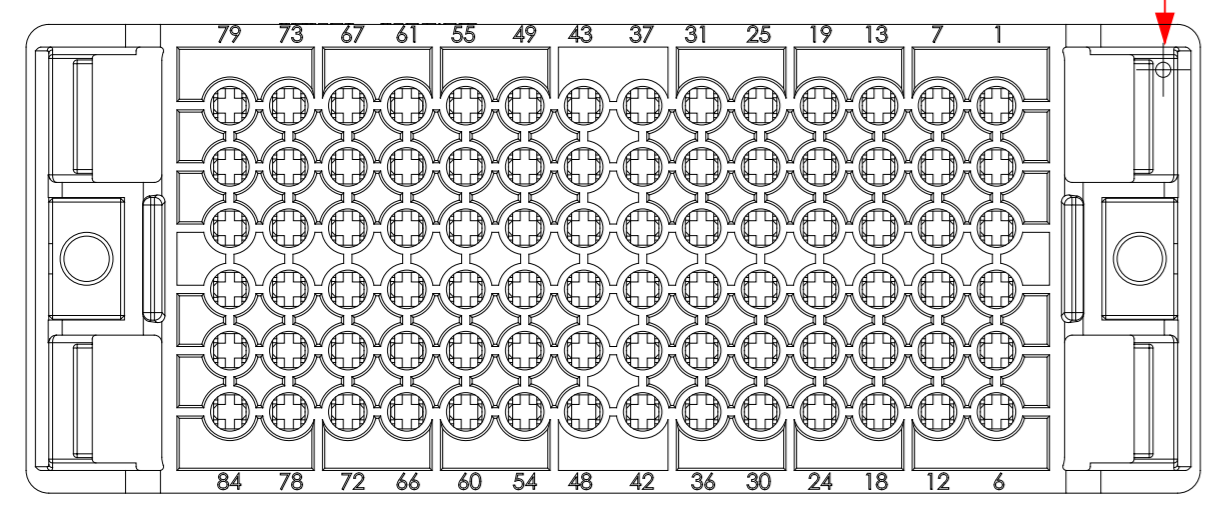

KEY REFERENCE HOLE

| Pos | CKT | GA | COL | Type | Term | Seal |
|-----|-----|----|-----|------|------|------|
| 1 | 243 | 12 | BLK | GXL | -</ | |

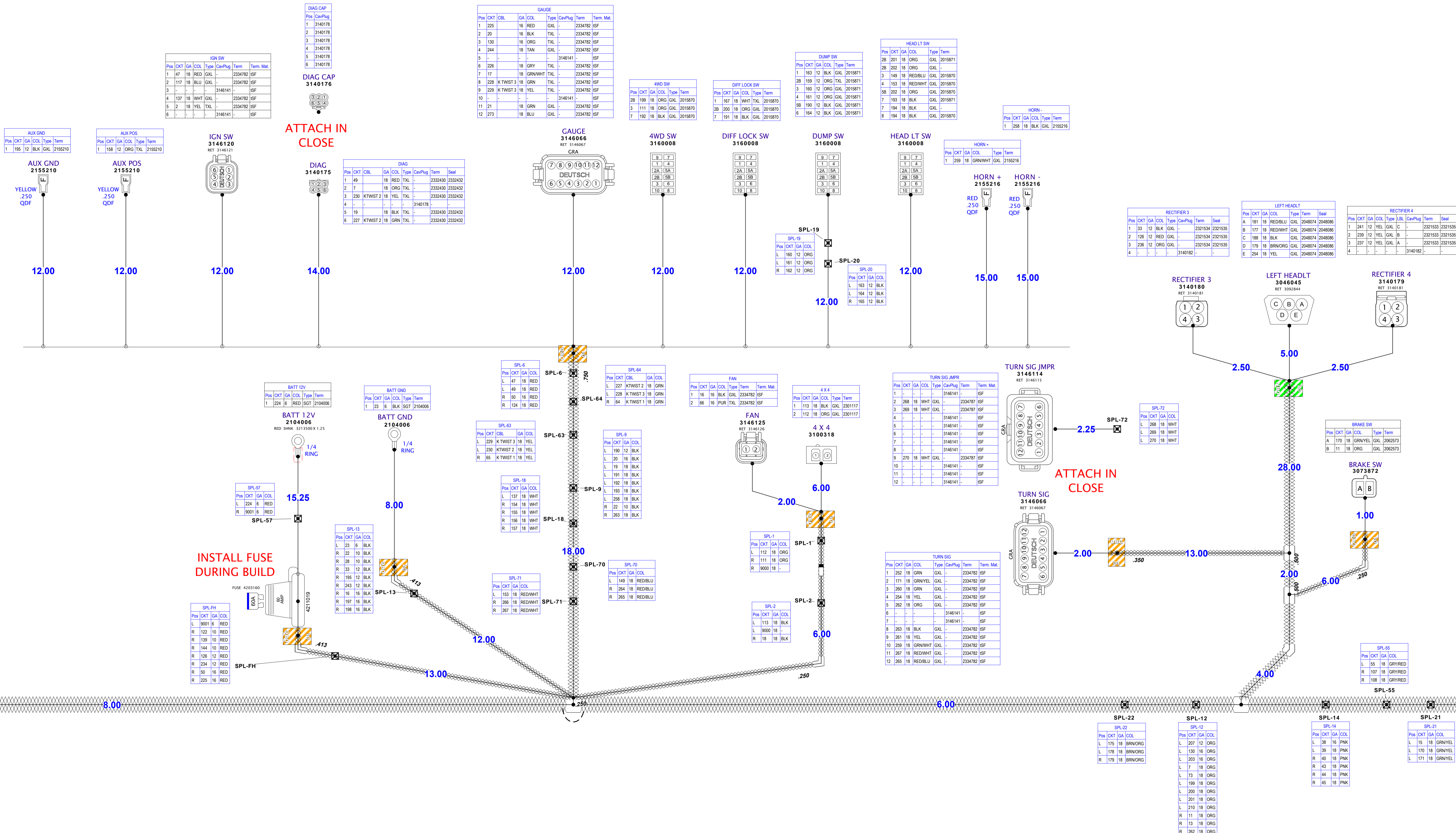

| Pos | CKT | GA | COL | Type | CavPlug | Term | Term. Mat. |
|-----|-----|----|-----|------|---------|---------|------------|
| 1 | 47 | 18 | RED | GXL | - | 2334782 | ISF |
| 2 | 117 | 18 | BLU | GXL | - | 2334782 | ISF |
| 3 | - | - | - | - | - | 3146141 | ISF |
| 4 | 137 | 18 | WHT | GXL | - | 2334782 | ISF |
| 5 | 2 | 18 | YEL | TXL | - | 2334782 | ISF |
| 6 | - | - | - | - | - | 3146141 | ISF |

| Pos | CavPlug |
|-----|---------|
| 1 | 3140178 |
| 2 | 3140178 |
| 3 | 3140178 |
| 4 | 3140178 |
| 5 | 3140178 |
| 6 | 3140178 |

| Pos | CKT | GA | COL | Type | CavPlug | Term | Term. Mat. | |
|-----|-----|-----------|-----|------|---------|---------|------------|-----|
| 1 | 225 | 16 | RED | GXL | - | 2334782 | ISF | |
| 2 | 20 | 16 | BLK | TXL | - | 2334782 | ISF | |
| 3 | 130 | 16 | ORG | TXL | - | 2334782 | ISF | |
| 4 | 244 | 18 | TAN | GXL | - | 2334782 | ISF | |
| 5 | - | - | - | - | - | 3146141 | ISF | |
| 6 | 226 | 18 | GRY | TXL | - | 2334782 | ISF | |
| 7 | 17 | 18 | GRN | WHT | TXL | - | 2334782 | ISF |
| 8 | 228 | K.TWIST 3 | 18 | GRN | TXL | - | 2334782 | ISF |
| 9 | 229 | K.TWIST 3 | 18 | YEL | TXL | - | 2334782 | ISF |
| 10 | - | - | - | - | - | 3146141 | ISF | |
| 11 | 21 | 18 | GRN | GXL | - | 2334782 | ISF | |
| 12 | 273 | 18 | BLU | GXL | - | 2334782 | ISF | |

| Pos | CKT | GA | COL | Type | Term |
|-----|-----|----|-----|------|---------|
| 1 | 163 | 12 | BLK | GXL | 2015871 |
| 2 | 159 | 12 | ORG | GXL | 2015871 |
| 3 | 160 | 12 | ORG | GXL | 2015871 |
| 4 | 161 | 12 | ORG | GXL | 2015871 |
| 5 | 190 | 12 | BLK | GXL | 2015871 |
| 6 | 164 | 12 | BLK | GXL | 2015871 |

| Pos | CKT | GA | COL | Type | Term |
|-----|-----|----|-----|------|---------|
| 1 | 167 | 18 | WHT | TXL | 2015870 |
| 2 | 200 | 18 | ORG | GXL | 2015870 |
| 3 | 111 | 18 | ORG | GXL | 2015870 |
| 7 | 191 | 18 | BLK | GXL | 2015870 |

| Pos | CKT | GA | COL | Type | Term |
|-----|-----|----|-----|------|---------|
| 1 | 163 | 12 | BLK | GXL | 2015871 |
| 2 | 159 | 12 | ORG | GXL | 2015871 |
| 3 | 160 | 12 | ORG | GXL | 2015871 |
| 4 | 161 | 12 | ORG | GXL | 2015871 |
| 5 | 190 | 12 | BLK | GXL | 2015871 |
| 6 | 164 | 12 | BLK | GXL | 2015871 |

| Pos | CKT | GA | COL | Type | Term |
|-----|-----|----|---------|------|---------|
| 2 | 201 | 18 | ORG | GXL | 2015871 |
| 3 | 149 | 18 | RED/BLU | GXL | 2015870 |
| 4 | 153 | 18 | RED/WHT | GXL | 2015870 |
| 5 | 202 | 18 | ORG | GXL | 2015870 |
| 7 | 163 | 18 | BLK | GXL | 2015871 |
| 7 | 194 | 18 | BLK | GXL | 2015871 |
| 8 | 194 | 18 | BLK | GXL | 2015871 |

| Pos | CKT | GA | COL | Type | Term |
|-----|-----|----|-----|------|---------|
| 1 | 258 | 18 | BLK | GXL | 2155216 |

| Pos | CKT | GA | COL | Type | Term | |
|-----|-----|----|-----|------|------|---------|
| 1 | 259 | 18 | GRN | WHT | GXL | 2155216 |

| Pos | CKT | GA | COL | Type | Term | Seal | |
|-----|-----|----|-----|------|------|---------|---------|
| 1 | 33 | 12 | BLK | GXL | - | 2321534 | 2321535 |
| 2 | 126 | 12 | RED | GXL | - | 2321534 | 2321535 |
| 3 | 236 | 12 | ORG | GXL | - | 2321534 | 2321535 |
| 4 | - | - | - | - | - | 3140182 | - |

| Pos | CKT | GA | COL | Type | Term | Seal |
|-----|-----|----|---------|------|---------|---------|
| A | 181 | 18 | RED/BLU | GXL | 2048074 | 2048086 |
| B | 177 | 18 | RED/WHT | GXL | 2048074 | 2048086 |
| C | 188 | 18 | BLK | GXL | 2048074 | 2048086 |
| D | 179 | 18 | BRN/ORG | GXL | 2048074 | 2048086 |
| E | 254 | 18 | YEL | GXL | 2048074 | 2048086 |

| Pos | CKT | GA | COL | Type | Term | Seal | |
|-----|-----|----|-----|------|------|---------|---------|
| 1 | 241 | 12 | YEL | GXL | C | 2321533 | 2321535 |
| 2 | 239 | 12 | YEL | GXL | B | 2321533 | 2321535 |
| 3 | 237 | 12 | YEL | GXL | A | 2321533 | 2321535 |
| 4 | - | - | - | - | - | 3140182 | - |

| Pos | CKT | GA | COL | Type | Term |
|-----|-----|----|---------|------|------|
| L | 55 | 18 | GRY/RED | - | - |
| R | 107 | 18 | GRY/RED | - | - |
| R | 108 | 18 | GRY/RED | - | - |

| Pos | CKT | GA | COL |
|-----|-----|----|---------|
| L | 175 | 18 | BRN/ORG |
| L | 178 | 18 | BRN/ORG |
| R | 179 | 18 | BRN/ORG |

| Pos | CKT | GA | COL |
|-----|-----|----|-----|
| L | 207 | 12 | ORG |
| L | 130 | 16 | ORG |
| L | 203 | 16 | ORG |
| L | 7 | 18 | ORG |
| L | 73 | 18 | ORG |
| L | 199 | 18 | ORG |
| L | 200 | 18 | ORG |
| L | 201 | 18 | ORG |
| L | 210 | 18 | ORG |
| R | 11 | 18 | ORG |
| R | 13 | 18 | ORG |
| R | 282 | 18 | ORG |

| Pos | CKT | GA | COL |
|-----|-----|----|-----|
| L | 38 | 16 | PNK |
| L | 39 | 18 | PNK |
| R | 40 | 18 | PNK |
| R | 43 | 18 | PNK |
| R | 44 | 18 | PNK |
| R | 45 | 18 | PNK |

| Pos | CKT | GA | COL |
|-----|-----|----|---------|
| L | 15 | 18 | GRN/YEL |
| L | 170 | 18 | GRN/YEL |
| L | 171 | 18 | GRN/YEL |



Property of Electrex, Inc. Drawing & information therein may only be used as authorized.
Customer: Intimidator Inc.

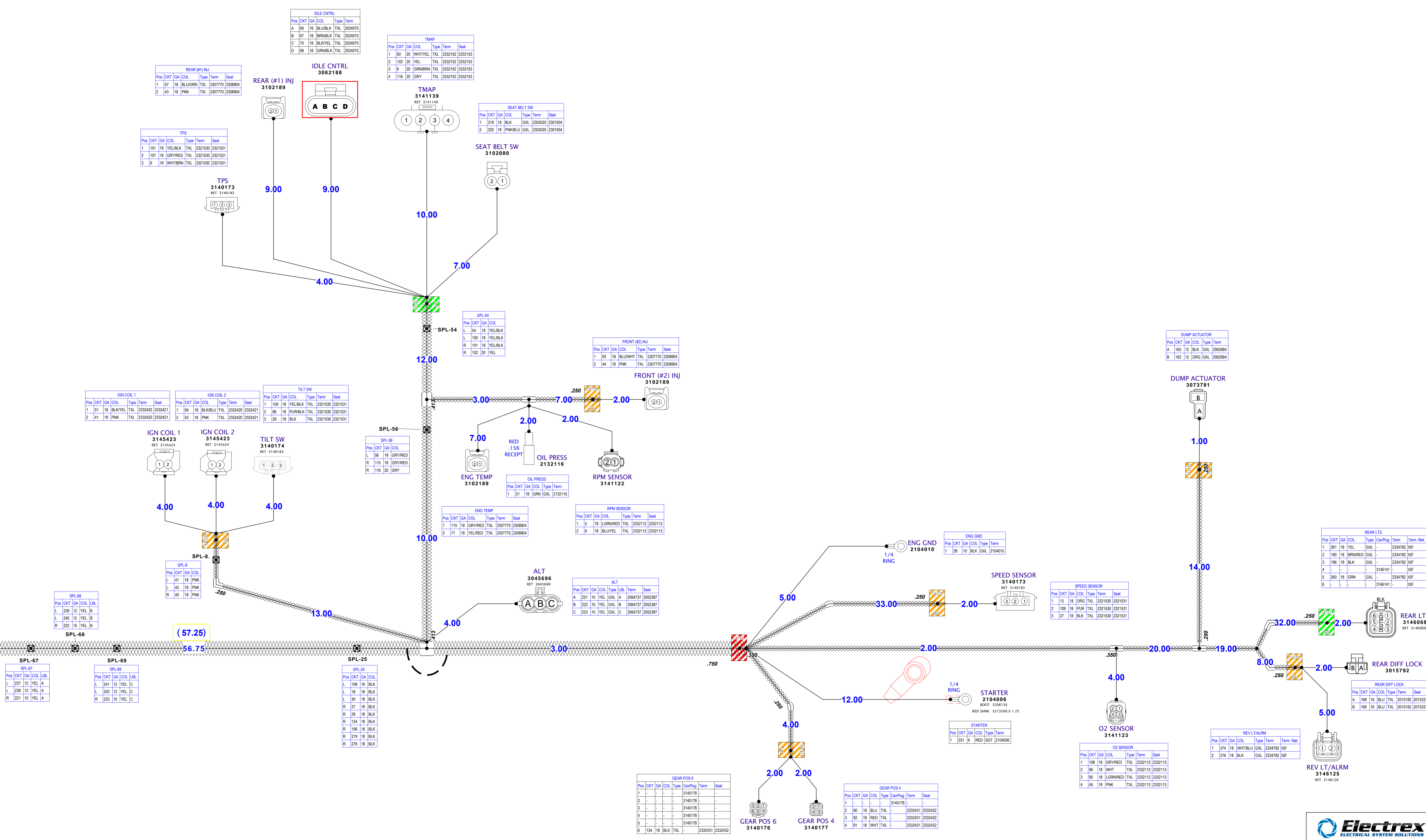

| Pos | CKT | GA | COL | Type | Term | Seal |
|-----|-----|----|---------|------|---------|---------|
| 1 | 57 | 18 | BLU/GRN | TXL | 2307770 | 2308904 |
| 2 | 43 | 18 | PNK | TXL | 2307770 | 2308904 |

| Pos | CKT | GA | COL | Type | Term | Seal |
|-----|-----|----|---------|------|---------|---------|
| 1 | 101 | 18 | YEL/BLK | TXL | 2321530 | 2321531 |
| 2 | 107 | 18 | GRV/RED | TXL | 2321530 | 2321531 |
| 3 | 9 | 18 | WHT/BRN | TXL | 2321530 | 2321531 |

| Pos | CKT | GA | COL | Type | Term | Seal |
|-----|-----|----|---------|------|---------|------|
| A | 69 | 18 | BLU/BLK | TXL | 2024075 | |
| B | 67 | 18 | BRN/BLK | TXL | 2024075 | |
| C | 70 | 18 | BLK/YEL | TXL | 2024075 | |
| D | 68 | 18 | GRN/BLK | TXL | 2024075 | |

| Pos | CKT | GA | COL | Type | Term | Seal |
|-----|-----|----|---------|------|---------|---------|
| 1 | 60 | 20 | WHT/YEL | TXL | 2332152 | 2332153 |
| 2 | 102 | 20 | YEL | TXL | 2332152 | 2332153 |
| 3 | 8 | 20 | GRN/BRN | TXL | 2332152 | 2332153 |
| 4 | 116 | 20 | GRY | TXL | 2332152 | 2332153 |

| Pos | CKT | GA | COL | Type | Term | Seal |
|-----|-----|----|---------|------|---------|---------|
| 1 | 219 | 18 | BLK | GXL | 2303025 | 2301934 |
| 2 | 220 | 18 | PNK/BLU | GXL | 2303025 | 2301934 |

| Pos | CKT | GA | COL | Type | Term | Seal |
|-----|-----|----|---------|------|---------|---------|
| 1 | 93 | 18 | BLU/WHT | TXL | 2307770 | 2308904 |
| 2 | 44 | 18 | PNK | TXL | 2307770 | 2308904 |

| Pos | CKT | GA | COL | Type | Term | Seal |
|-----|-----|----|---------|------|---------|---------|
| 1 | 51 | 18 | BLK/YEL | TXL | 2332420 | 2332421 |
| 2 | 41 | 18 | PNK | TXL | 2332420 | 2332421 |

| Pos | CKT | GA | COL | Type | Term | Seal |
|-----|-----|----|---------|------|---------|---------|
| 1 | 94 | 18 | BLK/BLU | TXL | 2332420 | 2332421 |
| 2 | 42 | 18 | PNK | TXL | 2332420 | 2332421 |

| Pos | CKT | GA | COL | Type | Term | Seal |
|-----|-----|----|---------|------|---------|---------|
| 1 | 100 | 18 | YEL/BLK | TXL | 2321530 | 2321531 |
| 2 | 86 | 18 | PUR/BLK | TXL | 2321530 | 2321531 |
| 3 | 29 | 18 | BLK | TXL | 2321530 | 2321531 |

| Pos | CKT | GA | COL | Type | Term | Seal |
|-----|-----|----|---------|------|------|------|
| L | 54 | 18 | YEL/BLK | | | |
| L | 100 | 18 | YEL/BLK | | | |
| R | 101 | 18 | YEL/BLK | | | |
| R | 102 | 20 | YEL | | | |

| Pos | CKT | GA | COL | Type | Term | Seal |
|-----|-----|----|---------|------|------|------|
| L | 54 | 18 | YEL/BLK | | | |
| L | 100 | 18 | YEL/BLK | | | |
| R | 101 | 18 | YEL/BLK | | | |
| R | 102 | 20 | YEL | | | |

| Pos | CKT | GA | COL | Type | Term | Seal |
|-----|-----|----|---------|------|---------|---------|
| 1 | 115 | 18 | GRY/RED | TXL | 2307770 | 2308904 |
| 2 | 71 | 18 | YEL/RED | TXL | 2307770 | 2308904 |

| Pos | CKT | GA | COL | Type | Term | Seal |
|-----|-----|----|---------|------|---------|---------|
| 1 | 5 | 18 | LG/RED | TXL | 2332112 | 2332113 |
| 2 | 6 | 18 | BLU/YEL | TXL | 2332112 | 2332113 |

| Pos | CKT | GA | COL | Type | Term | Seal |
|-----|-----|----|-----|------|------|---------|
| A | 221 | 10 | YEL | GXL | A | 2064737 |
| B | 222 | 10 | YEL | GXL | B | 2064737 |
| C | 223 | 10 | YEL | GXL | C | 2064737 |

| Pos | CKT | GA | COL | Type | Term | Seal |
|-----|-----|----|-----|------|------|------|
| L | 198 | 16 | BLK | | | |
| L | 18 | 18 | BLK | | | |
| L | 30 | 18 | BLK | | | |
| R | 27 | 18 | BLK | | | |
| R | 29 | 18 | BLK | | | |
| R | 134 | 18 | BLK | | | |
| R | 196 | 18 | BLK | | | |
| R | 219 | 18 | BLK | | | |
| R | 276 | 18 | BLK | | | |

| Pos | CKT | GA | COL | Type | Term | Seal |
|-----|-----|----|-----|------|------|---------|
| 1 | 221 | 10 | YEL | GXL | A | 2064737 |
| 2 | 222 | 10 | YEL | GXL | B | 2064737 |
| 3 | 223 | 10 | YEL | GXL | C | 2064737 |

| Pos | CKT | GA | COL | Type | Term | Seal |
|-----|-----|----|-----|------|---------|------|
| 1 | 221 | 6 | RED | SGT | 2104006 | |

| Pos | CKT | GA | COL | Type | Term | Seal |
|-----|-----|----|---------|------|---------|---------|
| 1 | 108 | 18 | GRY/RED | TXL | 2332112 | 2332113 |
| 2 | 96 | 18 | WHT | TXL | 2332112 | 2332113 |
| 3 | 95 | 18 | LG/RED | TXL | 2332112 | 2332113 |
| 4 | 45 | 18 | PNK | TXL | 2332112 | 2332113 |

| Pos | CKT | GA | COL | Type | Term | Seal |
|-----|-----|----|---------|------|---------|------|
| 1 | 274 | 18 | WHT/BLU | GXL | 2334782 | ISF |
| 2 | 276 | 18 | BLK | GXL | 2334782 | ISF |

| Pos | CKT | GA | COL | Type | Term | Seal |
|-----|-----|----|---------|------|---------|---------|
| 1 | 108 | 18 | GRY/RED | TXL | 2332112 | 2332113 |
| 2 | 96 | 18 | WHT | TXL | 2332112 | 2332113 |
| 3 | 95 | 18 | LG/RED | TXL | 2332112 | 2332113 |
| 4 | 45 | 18 | PNK | TXL | 2332112 | 2332113 |

| Pos | CKT | GA | COL | Type | Term | Seal |
|-----|-----|----|-----|------|---------|---------|
| 1 | - | - | - | - | 3140178 | - |
| 2 | - | - | - | - | 3140178 | - |
| 3 | - | - | - | - | 3140178 | - |
| 4 | - | - | - | - | 3140178 | - |
| 5 | - | - | - | - | 3140178 | - |
| 6 | 134 | 18 | BLK | TXL | 2332431 | 2332432 |

| Pos | CKT | GA | COL | Type | Term | Seal |
|-----|-----|----|-----|------|---------|---------|
| 1 | - | - | - | - | 3140178 | - |
| 2 | - | - | - | - | 3140178 | - |
| 3 | 90 | 18 | BLU | TXL | 2332431 | 2332432 |
| 3 | 92 | 18 | RED | TXL | 2332431 | 2332432 |
| 4 | 91 | 18 | WHT | TXL | 2332431 | 2332432 |



Property of Electra, Inc. Drawing & information therein may only be used as authorized.
 Customer: Intimidator Inc.
 Cust. P/N: 786-2084-00
 Rev: -
 DWG Title: 1000 TGB 2019 HRNS
 Our P/N: 9369066
 Date: Friday, August 17, 2018 7:29:24 AM
 Modified By: TW

| Length Tolerances | Unless Otherwise Specified: |
|-------------------|-----------------------------|
| < 6.0" | +0.00 -0.25" |
| 6.0" to 36.0" | +0.00 -0.50" |
| 36.0" to 72.0" | +0.00 -1.00" |
| > 72.0" | +0.00 -1.50" |